

Tornex Double High Counter

Effective Smoking Area Control



High standing, high efficiency, mobile filtration counter

Double High Counters are a highly efficient, creative, solution for most applications including enclosed smoking rooms and open areas. They can enhance the environment in an existing smoking room and have also proven to be an ideal solution as smoking points in airports.

Product Description

The Tornex Double High Counter utilises two Tornex filtration systems and can process 30m³ of air per minute. The double units use direct absorption to collect smoky air before passing it through two 'three stage' filtration systems and returning it to atmosphere as cleaned air.



Features

- **2 x Pre-Filter** - A fine mesh removes visible dust
- **2 x Electrical Dust Collector (EDC)** – Electrically charges the smoke and other particles and catches them with a polarised board.
- **2 x Deodorising Filter** – Activated Charcoal filter purifies the smoky air and reduces odours.
- **2 x Twin Centrifugal Fans** – Connected to Direct drive electric motors to draw air through the 3 stage filtration system.
- **Motion Sensor** – Counters are only operational when movement is detected.

Service & Maintenance

All Tornex installations require regular maintenance for optimum efficiency, Tornex recommend a full after-sales service contract.

Maintenance frequency is dependant on the number of smokers; number of cigarettes smoked and air circulation.

Tornex will advise of the appropriate frequency after the first service.

Options

- Self extinguishing ash trays
- Custom Finishes
- Advertising panels

Advertising

Another key benefit is the appeal of advertising space. The units can generate significant revenue through the leasing of space on the unit panels. Areas situated in the retail sectors of airports have noticeably boosted sales

Specification

Double High Counter	CE	
Dust Collection Efficiency (DOP Method)	96% (0.8um) / 94% (0.3um)	
Processed Amount (M ³ /min)	High 30	Low 20
Air Output Amount (M ³ /min)	High 20	Low 15
Standard Capacity	8 People	
Electrical Supply	240v /1/ 50Hz	
Electrical Consumption	150W	120W
Pre Filter	SUS 24 Mesh	
EDC	2 Stage Electrical Dust Collector	
Deodorising Filter	Charcoal	
Material	Body: Steel Melamine Coating	
Dimensions (mm)	W1800 x D1000 x H1150 mm	
Weight	Approx 150 Kg	



Double High Counter Configurations

Standard Double High Counter

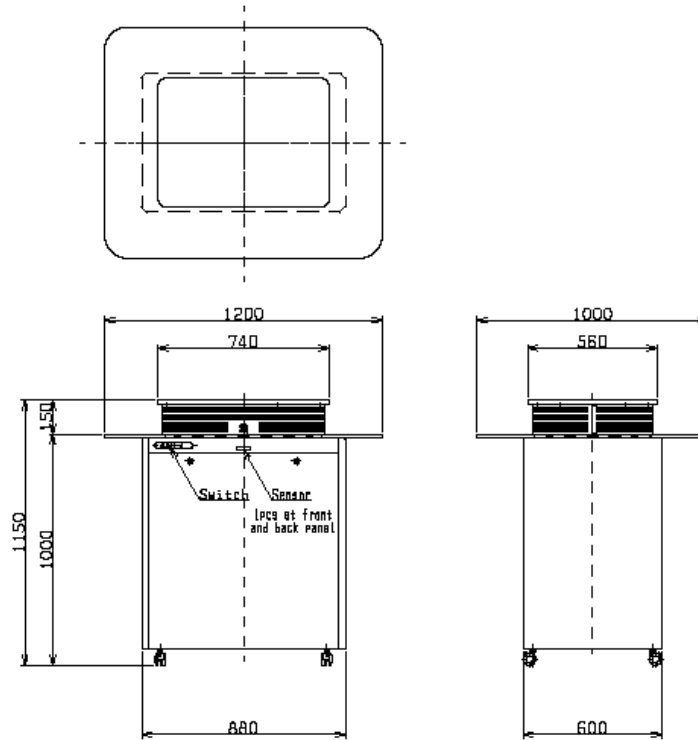

Double High Counter with Self Extinguishing Ashtrays

